

# High-voltage Energy Storage Batteries

User manual

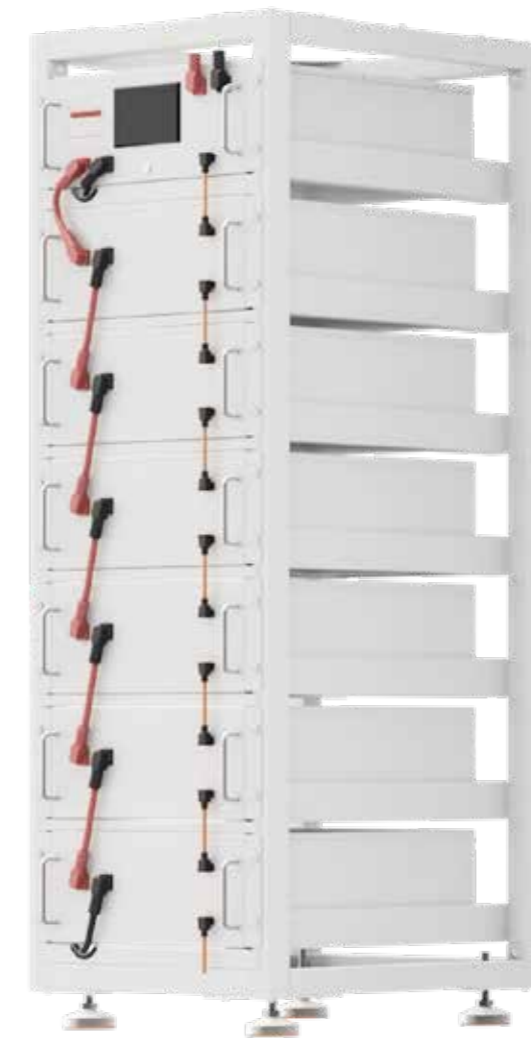

# Important safety instructions

Please keep this manual for future reference

This manual contains all safety, installation and operating instructions for the High voltage energy storage batteries.

Please read all instructions and precautions in the manual carefully before installation and use.

## Contents

<b>1. Instructions for use</b>	<b>1~2</b>
1.1 Usage Guidelines	1
1.2 Instructions for system composition	1
1.3 General safety information	1
1.4 Disclaimer	2
1.5 Proper use	2
1.6 Operator requirements	2
<b>2. Safety</b>	<b>3</b>
2.1 Safety rules	3
2.2 Safety information	3
<b>3. Transportation</b>	<b>3~5</b>
3.1 Regulations for battery pack transportation	3~4
3.2 Moving the battery modules	5
<b>4. Tools preparation</b>	<b>5~6</b>
4.1 Necessary Installation Tools	5
4.2 Personal Protective Equipment +1000 Vdc Insulated Tools	5~6
<b>5. Installation precautions</b>	<b>6~30</b>
5.1 Battery energy storage system instructions	6~7
5.2 System Parameters	7
5.3 Cabinet description	8~9
5.3.1 Cabinet parts description	8
5.3.2 Cabinet assembly instructions	9
5.4 Installing the module to the cabinet	9~10
5.5 Install the wiring harness	10
5.6 Schematic diagram of the connection	11~12
5.7 Schematic diagram of the communication connection	13~14
5.8 Battery module description	15~16
5.9 High voltage BCU box instructions	16~29
5.10. Screen instructions	29~30
<b>6. Maintain and upgrade</b>	<b>30</b>
6.1 System maintenance	30
6.2 System upgrade	30
<b>7. Store of the batteries</b>	<b>30</b>
<b>8. Disposal of waste batteries</b>	<b>30</b>
<b>9. Maintenance and conservation</b>	<b>31</b>
<b>10. Product Warranty Record Card</b>	<b>32</b>

## 1. Instructions for use

Thank you very much for choosing the series of home energy storage systems developed and produced by our company. Please be careful before installing and using the product. Read and understand all of this manual. If you have any suggestions during use, please feel free to give us feedback.

### 1.1 Usage Guidelines

This installation and operation manual is intended for modular battery energy storage systems. Please read this installation and operation manual carefully to ensure the reliable installation, commissioning and maintenance of the equipment. Installation, commissioning, and maintenance must be carried out by qualified authorized personnel. Keep this installation and operation manual and other applicable documents near the battery storage system so that all personnel involved in installation or maintenance can refer to this installation and operation manual at any time.

This installation and operation manual is only available in countries that meet certification requirements. Please comply with applicable local laws, regulations and standards. The standards and legal provisions of other countries may not be consistent with the provisions and norms of this manual. In this case, please contact our after sales.

### 1.2 Instructions for system composition

Components	Quantity	Specifications
4U battery module	4-8	51.2V100Ah
BCU	1	200V-700V/100A
Cabinet	1	548×584×1900mm

### 1.3 General safety information

1. Improper use can result in death. The operator of the device must read this manual and follow all safety information.
2. The operator of this equipment must follow the specifications in this manual.
3. This manual cannot describe all possible situations. Therefore, always give priority to applicable standards and relevant occupational health and safety (OH&S) regulations.
4. In addition, installation may involve safety hazards if:

Installation is not correct.

Installation by someone who has not received relevant training or instruction.

Failure to follow the warnings and safety information in this manual.



**Danger! Failure to follow safety messages can lead to life-threatening situations.**

### 1.4 Disclaimer

No liability for personal injury, property damage, product damage, or subsequent loss is accepted under the following circumstances.

1. Failure to comply with the provisions of this manual.
2. Improper use of this product.
3. Unauthorized or unqualified personnel repair the product, remove the frame and perform other operations.
4. Use of unapproved spare parts.
5. Unauthorized modifications or technical changes to the product.

### 1.5 Proper use

1. Battery energy storage systems can only be installed and operated in enclosed spaces. The working environment temperature range is  $-20^{\circ}\text{C}$ ~ $55^{\circ}\text{C}$ , the maximum humidity is 85%. The battery module should not be exposed to sunlight or placed directly next to a heat source.
2. The battery module should not be exposed to corrosive environments.
3. When installing the battery storage system, ensure that it is located on a sufficiently dry and flat surface, and has sufficient carrying capacity. The elevation of the installation site shall not exceed 2000 meters without the written approval of the manufacturer. The output power of the battery decreases with increasing altitude.
4. In areas where flooding is possible, care must be taken to ensure that the battery module is installed at the right height and to prevent contact with water.
5. The battery storage system must be installed in a fireproof room. The room must have no fire source, and must be equipped with independent fire prevention devices.
6. Following the specifications in this manual is also part of proper use. The use of this battery storage system is prohibited under the following circumstances:

- ① Mobile use on land or in the air (use on water only with the written consent of the manufacturer).
- ② For use in medical devices.
- ③ Used as a UPS system.
- ④ In other disputed cases, the manufacturer's written consent is required.

### 1.6 Operator requirements

All operation shall comply with applicable local regulations and standards. Installation of this system should only be done by electricians with the following qualifications:

1. Trained to deal with the hazards and risks associated with the installation and operation of electrical equipment, systems and batteries.
2. Trained in the installation and commissioning of electrical equipment.
3. Understand and comply with technical connection conditions, standards, guidelines, regulations and applicable laws.
4. Knowledge of handling lithium-ion batteries (transport, storage, disposal, hazardous sources).
5. Understand and comply with this document and other applicable documents.

## 2. Safety

### 2.1 Safety rules

To avoid property damage and personal injury, the following rules should be followed when working on dangerous live parts of battery energy storage systems:

1. The device is working properly.
2. Make sure it doesn't restart.
3. Make sure there is no voltage.
4. Ensure ground protection and short circuit protection.
5. Cover or shield adjacent live parts.

### 2.2 Safety information

Be aware that damaged or short-circuited parts may cause electrocution and death hazards. Connecting battery terminals may cause a short circuit, which can cause current to flow. This type of short circuit must be avoided under all circumstances. Therefore, follow these instructions:

1. Use insulating tools and gloves.
2. Do not place any tools or metal parts on the battery pack module, high voltage BCU or inverter.
3. When operating the battery, be sure to remove the watch, ring and other metal objects.
4. Do not install or operate this system in explosive or high humidity areas.
5. When operating the energy storage system, first turn off the charge controller, then turn off the battery, and make sure the charge controller and battery do not turn on again. Improper use of battery energy storage systems can result in death. Use of battery energy storage systems beyond their intended use is not allowed, as this may pose significant risks. Improper operation of battery energy storage systems can result in life-threatening risks, serious injury or even death.

**Attention!** Warning! Improper use may damage the battery unit.

1. Do not expose the battery module to rain or immerse it in liquid.
2. Do not expose the battery module to corrosive environments such as ammonia and salt.
3. The battery energy storage system should be debugged within three months after delivery.

## 3. Transportation

### 3.1 Regulations for battery pack transportation

Must comply with the relevant laws and regulations of the corresponding country on the transportation of lithium ion batteries on the road.

 Smoking is prohibited in the vehicle during transportation or in the vicinity during loading and unloading.

 Dangerous goods transport vehicles shall comply with the relevant regulations for road transport and be equipped with two tested carbon dioxide fire extinguishers.



It is forbidden for freight forwarders to open the outer packaging of battery modules. Only use approved lifting equipment to move the battery tank system. Use only the lifting lugs at the top of the battery cabinet as connection points. When lifting, the sling must be at an angle of at least 60°.



Improper vehicle transport can cause personal injury. Improper transportation or improper transportation locking can cause the load to slip or overturn, which can result in injury. The battery pack should be placed vertically to prevent it from sliding inside the vehicle and secured with a holding strap.



Tilting the battery holder can cause personal injury. Battery holders can weigh up to 400kg maximum. When tilted, they can tip over, causing personal injury and damage. Make sure that the battery holder is on a stable surface and that it will not tilt due to load.



Battery storage systems can be damaged if not transported properly. Battery modules can only be transported vertically. Be aware that these parts can be top-heavy. Failure to follow this instruction may result in damage to the part.



The battery storage cabinet installed with the battery module may be damaged during shipping. Battery storage cabinets are not designed to be shipped with an already installed battery module. Make sure the battery module, BCU, inverter, and battery cabinet are shipped separately. Do not move the battery holder or use lifting equipment to lift the battery holder after installing the battery module.



If possible, do not remove the shipping packaging until you arrive at the installation site. Check the shipping packaging for damage before removing the shipping protector. Otherwise, shipping damage cannot be ruled out.



Improper transportation of battery modules may result in personal injury. A Cell battery module can weigh up to 40kg. If it falls or slips, it could cause personal injury and possibly damage the battery module. Proper transport and lifting equipment must be used to ensure safe transport.



Wear safety shoes, and when transporting battery cabinet and battery modules, the parts may be crushed due to excessive weight. Therefore, all personnel involved in the transport must wear safety shoes with toe tips. Follow the safety regulations for the end customer's on-site transportation, especially during loading and unloading.



There is an increased risk of injury during transportation and installation of unpacked battery storage cabinets, especially on sharp metal plates. For this reason, protective gloves must be worn by all those involved in the transportation and installation.











The components of the energy storage system are heavy. We recommend having at least 2-3 people together to install the battery holder. Lifting gear helps with heavy parts, while pulleys or carts help with lighter parts. Be careful not to damage the box. The number of stacked battery modules should not be too heavy.

### 3.2 Moving the battery modules

The battery module can only be carried in the upright position. Be aware that battery holders can be top-heavy.

## 4. Tools preparation

### 4.1 Necessary Installation Tools

			
Multimeter + Current clamp	Insulated Screwdriver Set	Insulated Allen Key Set from 2 mm to 8 mm	Drill+Hammer
			
Electrician Scissors	Insulated Torque Wrench Set	Lifting Strap + Mechanical Lifter	RS485/USB +Screw Terminal (insulated)

### 4.2 Personal Protective Equipment +1000 Vdc Insulated Tools



Auxiliary tools and materials

Tools	Effect
Cross screwdriver	Caulk plate secure
10mm hex socket	Secure the expansion screws
5mm hex wrench	M6*14 hex head screws
Materials	Action
Fastening material (M6*14 hex socket screws, M6*100 expansion screws, M3X6 cross countersunk head screws)	<ol style="list-style-type: none"> <li>1. Assemble the battery holder and attach it to the wall or connect two battery holders.</li> <li>2. Assemble the battery module, high voltage BCU and fix it to the cabinet.</li> <li>3. The curtain plate is fixed.</li> </ol>

## 5. Installation precautions



**Warnings! Electrostatic overload may cause damage to equipment**

1. The total weight of the battery storage system can be up to 400 kg. Make sure the installation site has sufficient carrying capacity.
2. When selecting the installation location, transport routes and necessary site cleaning should be considered.

### 5.1 Battery energy storage system instructions

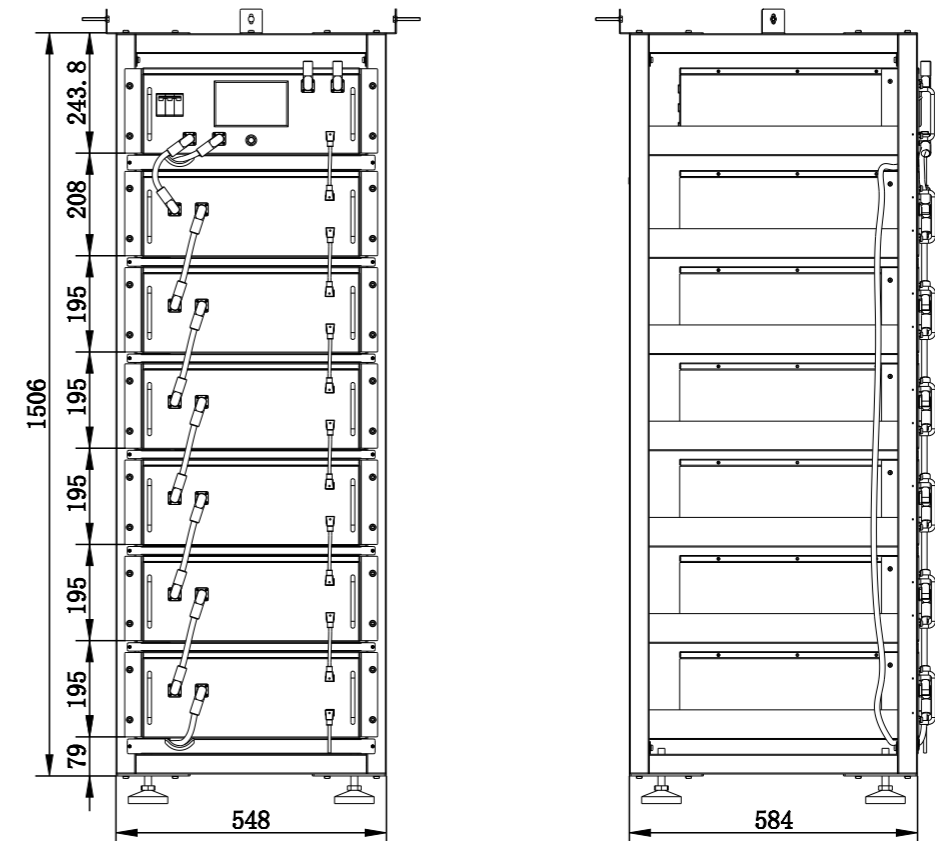



The energy storage system is a high-voltage lithium-ion battery system. It provides a reliable backup power for supermarkets, banks, schools, farms and small businesses to smooth load curves and achieve peak load transfer. It also improves the stability of the renewable energy system and promotes the application of renewable energy. It has the characteristics of high integration, good reliability, long cycle life, wide range and wide operating temperature range.

Modular design of battery energy storage system. Each battery module has a capacity of 5.12Kwh. 6 battery modules are supported in series with a total energy of 30.72Kwh.

More capacity requirement, please contact supplier.

## 5.2 System Parameters

Model	HVM64S100BL-U	HVM96S100BL-U
Module presentation		
Energy Capacity	100Ah	100Ah
Standard Voltage	204.8V	307.2V
Rated energy	20.48KWh	30.72KWh
Product Dimensions	548×584×1500mm	548×584×1500mm
Net Weight	235Kg	340Kg
Standard Charge Current	20A	20A
Maximum discharge current	100A	100A

Model	HVM128S100BL-U	HVM160S100BL-U
Module presentation		
Energy Capacity	100Ah	100Ah
Standard Voltage	409.6V	512V
Rated energy	40.96KWh	51.2KWh
Product Dimensions	548×584×1950mm	548×584×2300mm
Net Weight	425Kg	510Kg
Standard Charge Current	20A	20A
Maximum discharge current	100A	100A

Operating temperature	Altitude	Level of protection
Charge: 0 ~ 55 °C Discharge: -15 ~ 65 °C	≤2000m	IP21

## 5.3 Cabinet description

### 5.3.1 Cabinet parts description

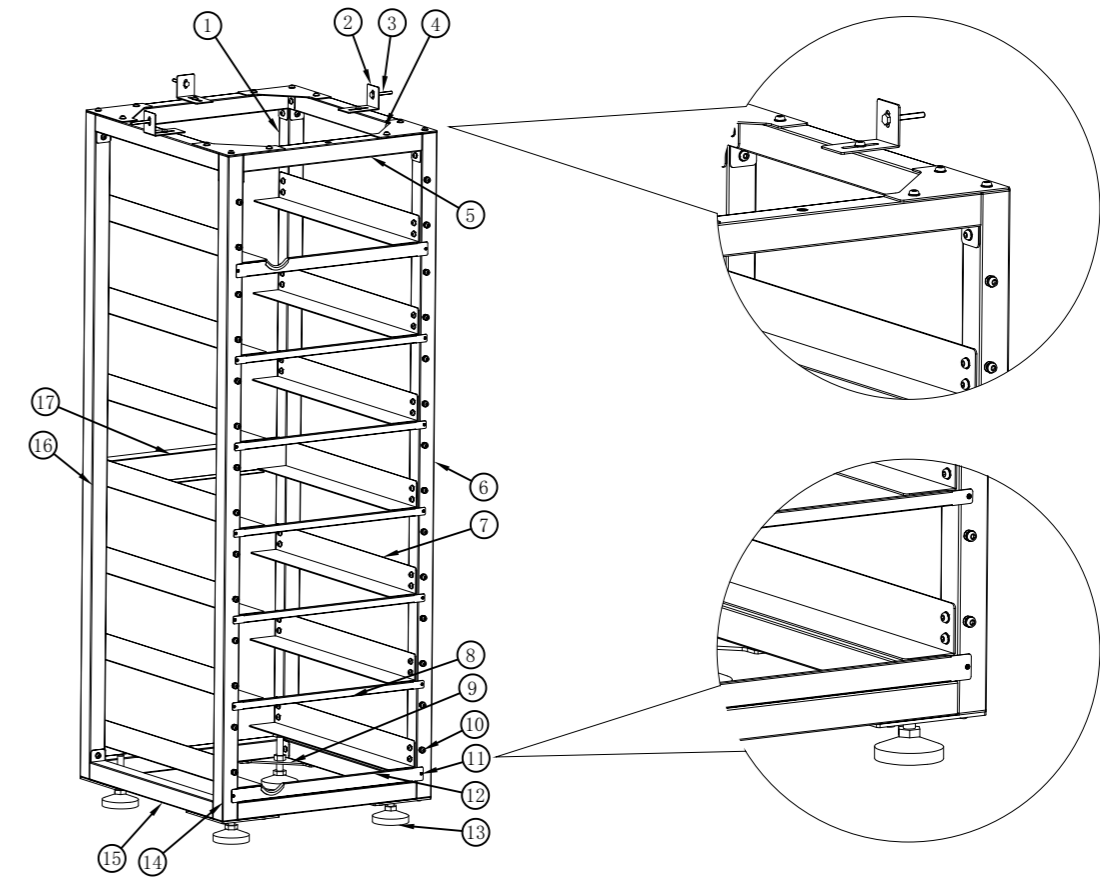

ID	First name	Quantity	Notes
1	Right-rear post	1	
2	Wall fixtures	3	
3	M6X50 expansion screws	3	Secure with the wall
4	Triangle retaining plate	4	
5	Front and rear - short beam	4	
6	Right - front post	1	
7	Layer pallet	14	
8	Small-caulk board	5	
9	Foot base plate (screws fully welded)	4	
10	M6X14 hex socket locking screws	136	Secure cabinet as well as chassis
11	M3X6 cross countersunk head screws	14	Secure caulk board
12	Large - caulk board	2	
13	Metal foot	4	M14*100 (bottom) 80 (bearing 260KG)
14	Left - front post	1	
15	Left and right - long beam	4	
16	Left - rear post	1	
17	Middle - reinforcing board	1	

### 5.3.2 Cabinet assembly instructions

1. Take out two beams and two posts to form the frame, connect them with connectors and fix them with M6X14 hex socket locking screws.
2. Assemble the two sets of frames in the same manner as before and complete the assembly for spare.
3. Connect the assembled frames with long beams and secure them with M6X14 hex socket locking screws.
4. Install the connecting block and the middle reinforcing block to the frame in turn to ensure that the frame as a whole is firm and stable.
5. Attach the wall fasteners to the frame, and use M6 expansion screws to fix the frame and wall.

**Note:** Please read this manual for reference.

### 5.4 Installing the module to the cabinet



**Insufficient or no grounding can result in electric shock. Faulty, under-grounded, or ungrounded equipment can result in damage to the equipment and a life-threatening electric shock.**



**Note:** Turn the manual switch on the high voltage BCU to the off position before installing the battery.

Insert a battery module into the first-level position of the battery cabinet; then continue mounting in the same manner from bottom to top until you reach the sixth level. At the seventh level, insert the high voltage BCU.

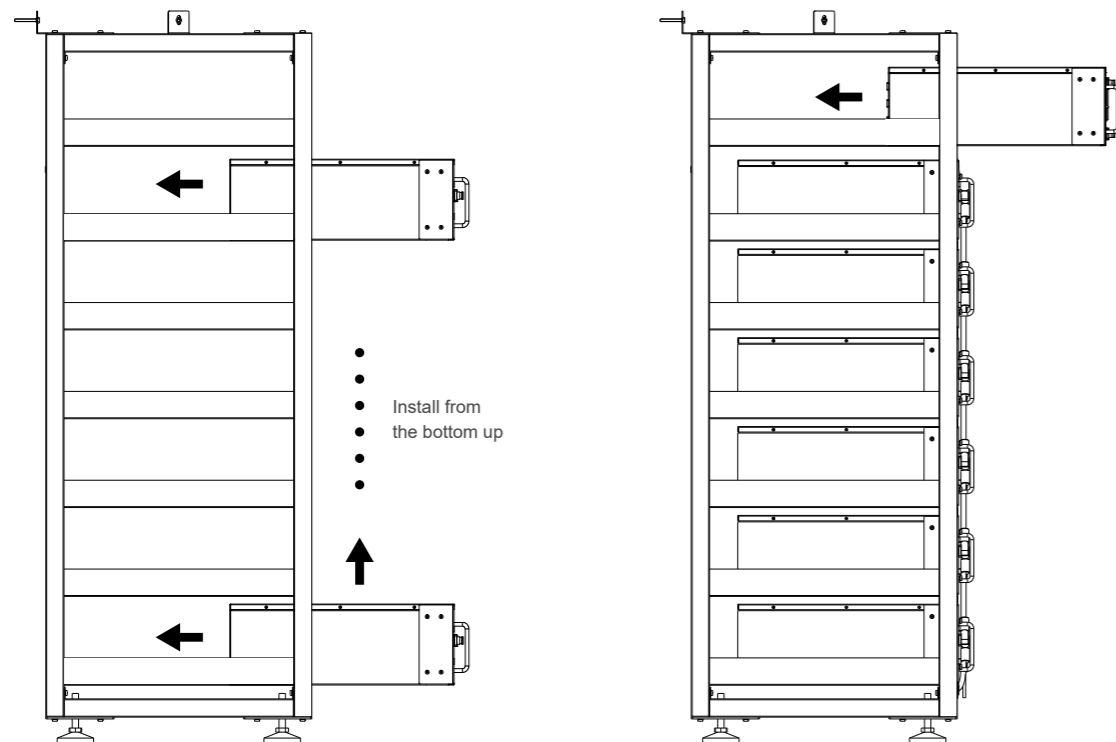

After inserting the battery module and high voltage BCU into the cabinet, secure the battery module and high voltage BCU to the rack using M6\*15 outer hex combination screws.

### 5.5 Install the wiring harness

#### Wiring harness installation steps:

1. Complete the installation of the battery pack and the high-voltage control box and rack.
2. Install 6 CAN communication harnesses to the output and input communication ports of the battery pack and high-voltage control box in turn.
3. Connect 6 battery packs in series with wiring harnesses, and connect the battery packs and high-voltage control boxes in series in turn.
4. Connect the negative pole of the bottom battery pack to the negative pole of the control box with the B-wire harness, note that the wiring harness needs to be threaded from the back to the front.

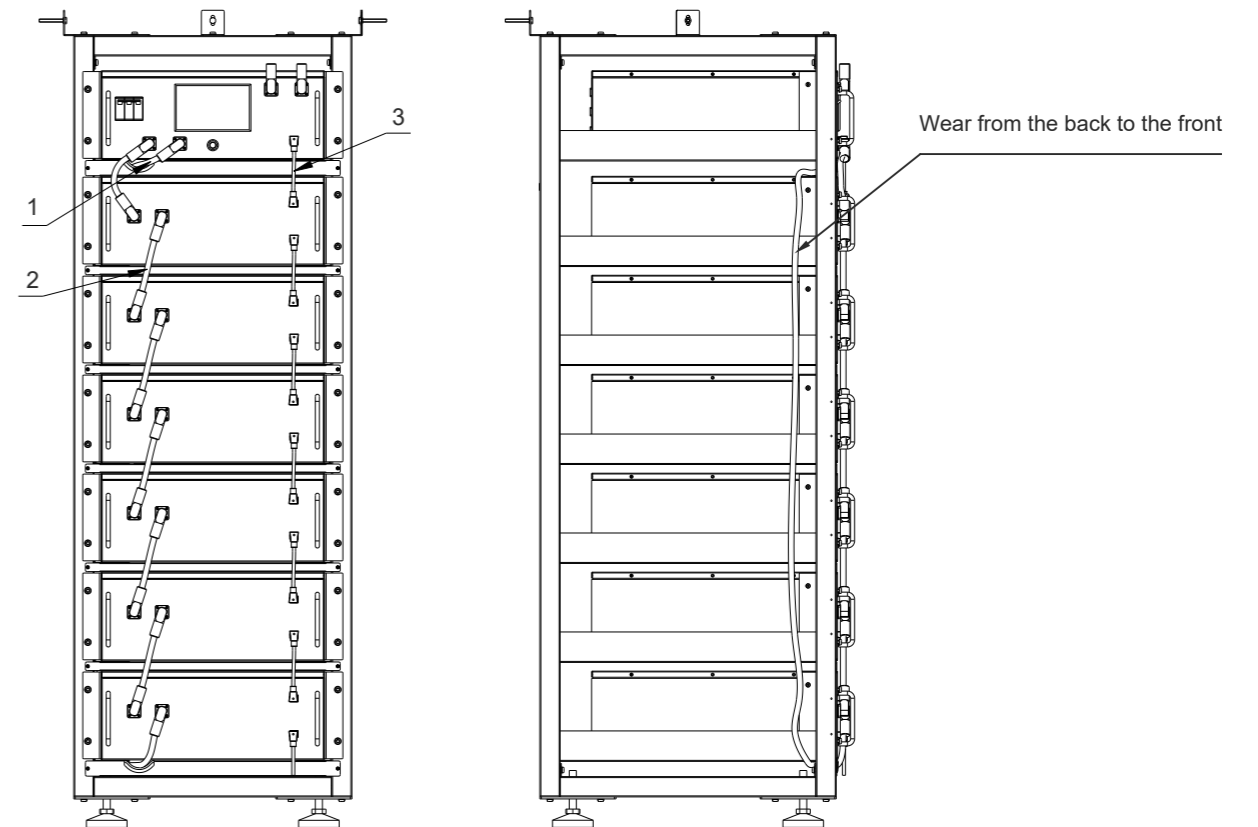

Serial Number	Name	Quantity
1	B- Harness	1
2	Battery series harness	6
3	CAN communication harness	6

## 5.6 Schematic diagram of the connection

### A battery connection

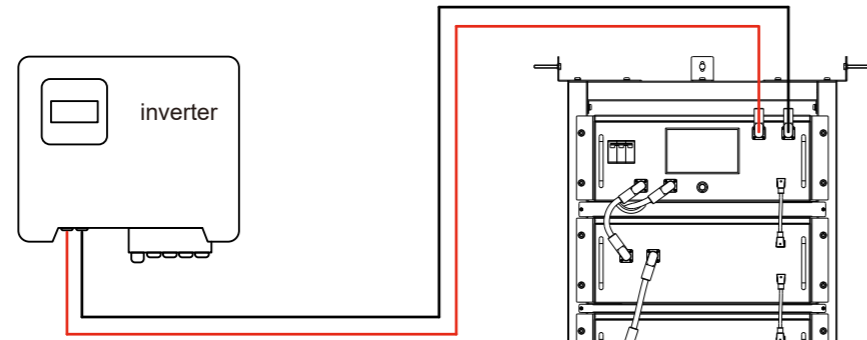

### Connection of two batteries

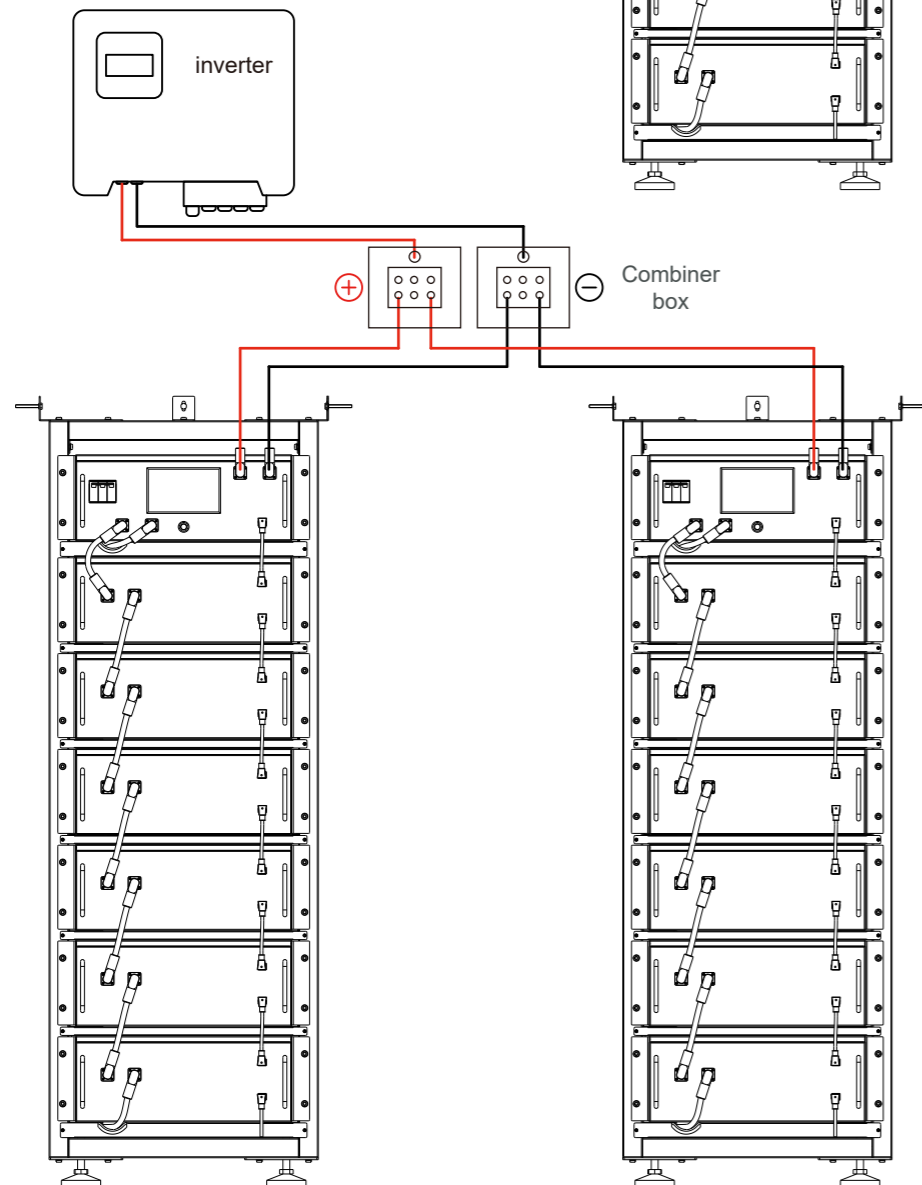

### Connection of three batteries

Note: Up to three products can be connected at the same time.

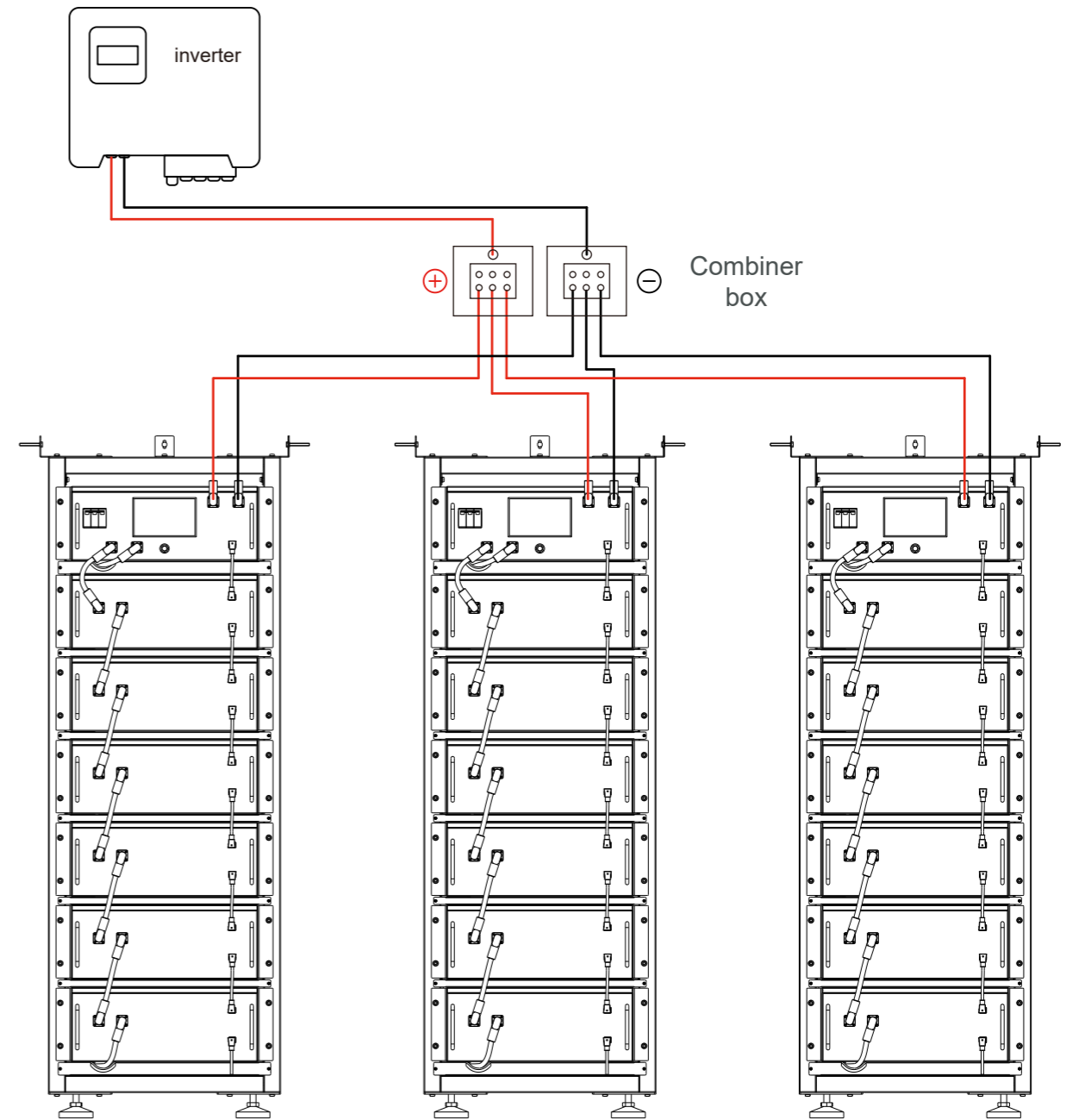

Note: When multiple clusters are connected in parallel, the connection method, wire diameter and length from the battery cluster to the combiner box should remain the same to ensure balanced current in each cluster.

## 5.7 Schematic diagram of the communication connection

### A battery BMS connection

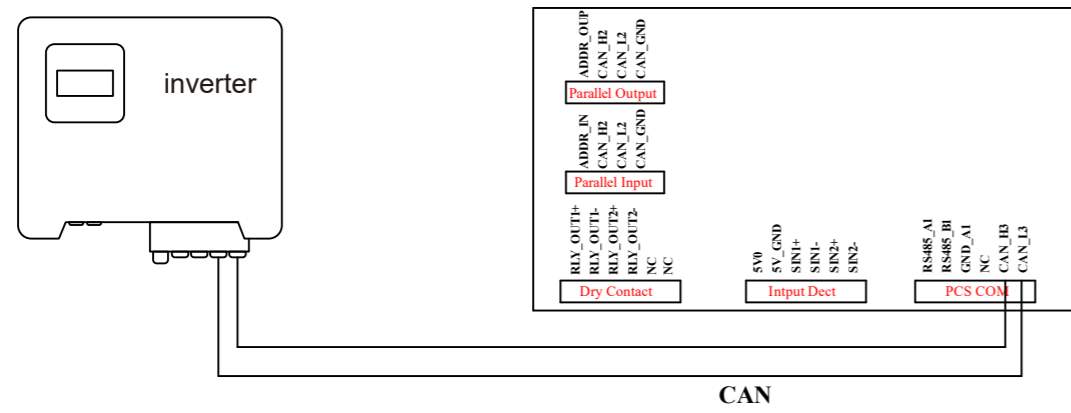

### Connection of two battery BMS

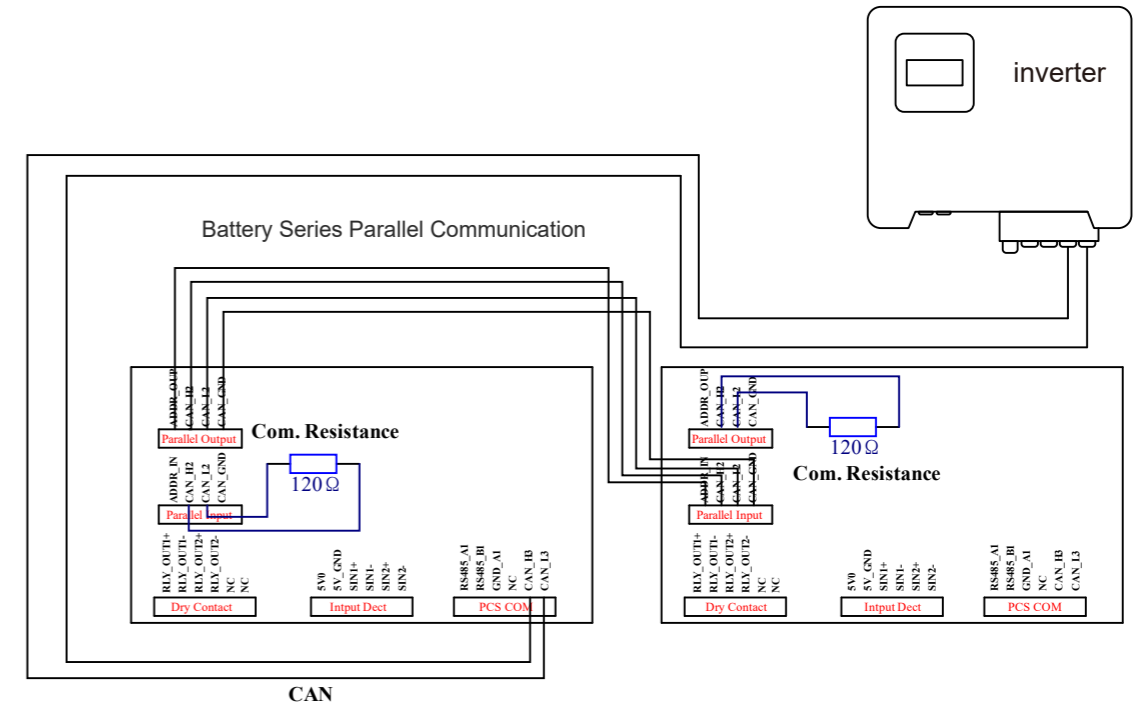

### Connection of three battery BMS

Note: Up to three products can be connected at the same time.

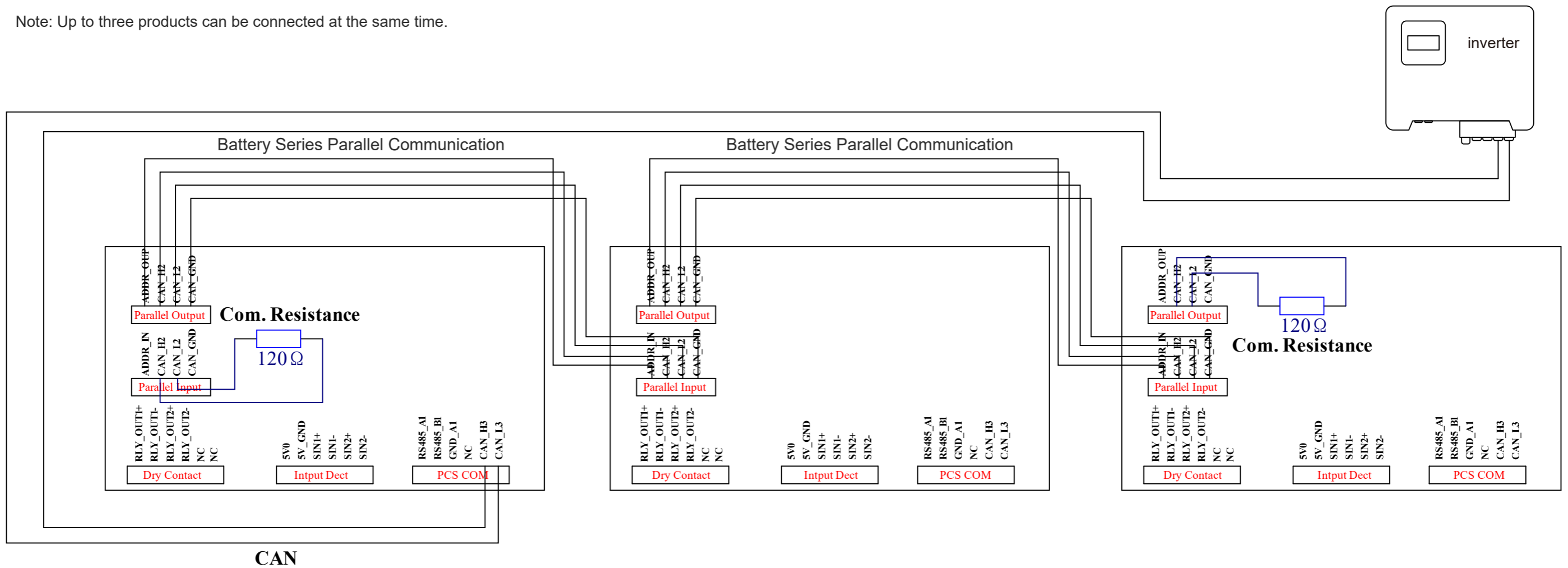

## 5.8 Battery module description

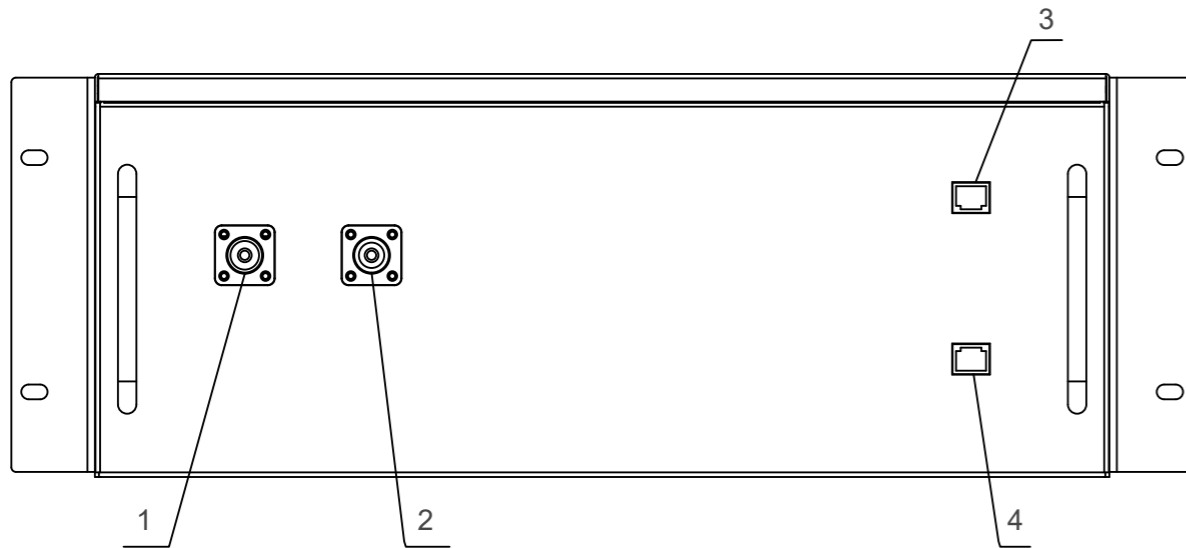

Battery module port description		
ID	Name	Instructions
1	B+	Battery pack positive (orange)
2	B-	Battery pack negative (black)
3	Cascade input	Connection port for battery module communication and power input
4	Cascade output	Connection port for battery module communication and power output

Battery module parameters			
ID	Items	Specifications/parameters	Remarks
1	Battery type	LiFePO <sub>4</sub>	
2	Rated voltage	51.2V	

3	Rated capacity	100Ah	0.2CA
4	Energy	5.12KWh	
5	Standard charge and discharge ratio	0.2 C	
6	Maximum charge and discharge rate	1 C	
7	Level of protection	IP21	
8	Dimensions (W x D x H)	485×445×175mm	
9	Weight	~42kg	

## 5.9 High voltage BCU box instructions

### Front Panel

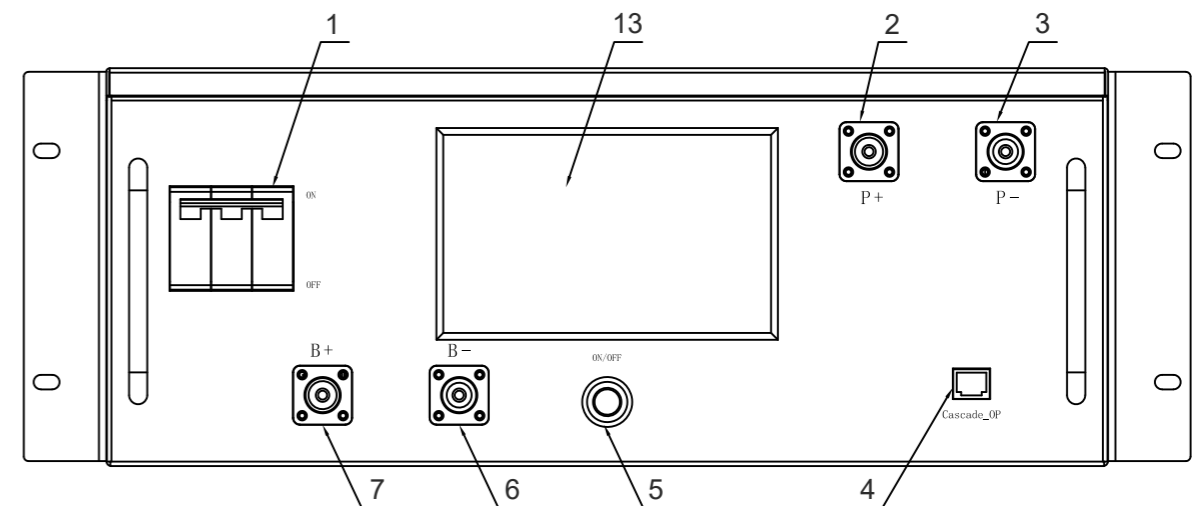

## Back panel

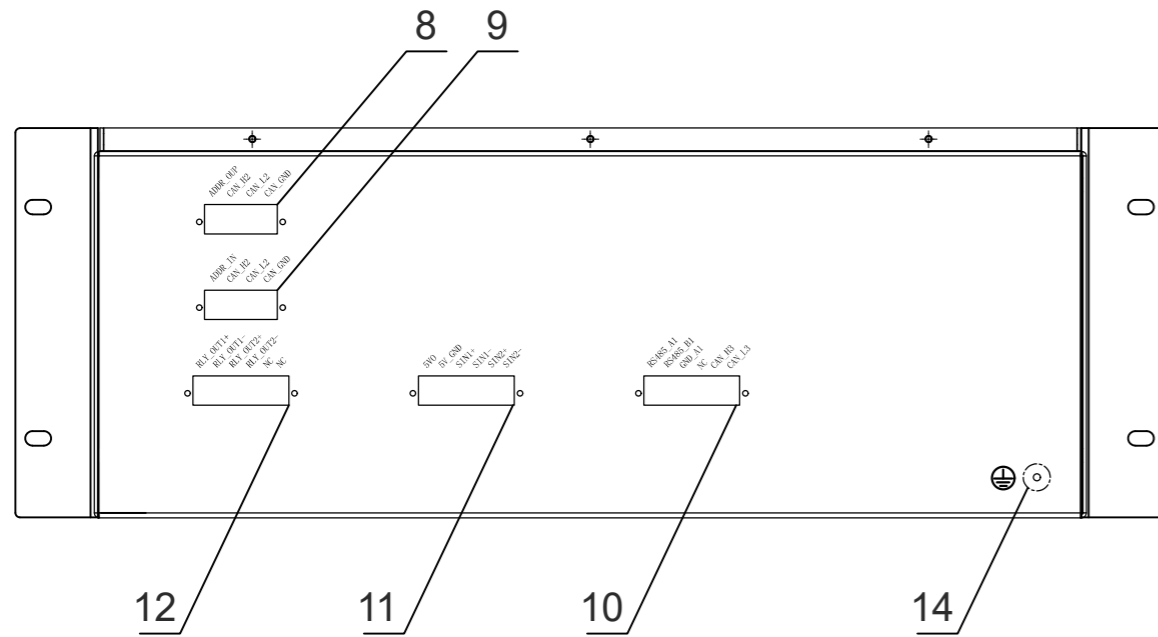

ID	Interface Type	Pin Name		Description	Location
		Pin Name	Description		
8	Parallel output interface (Cluster parallel operation)	ADDR_OUP	Local communication code output	Rear Panel	
		CAN_H2	Local CAN communication		
		CAN_L2	Local CAN communication		
		CAN_GND	CAN communicate		
9	Parallel input interface (Cluster parallel operation)	ADDR_IN	Local communication code output	Rear Panel	
		CAN_H2	Local CAN communication		
		CAN_L2	Local CAN communication		
10	External communication interface	RS485-A1	Local RS485 communication	Rear Panel	
		RS485-B1	Local RS485 communication		
		GND_A1	Local RS485-A1 communication ground		
		NC	empty		
		CAN_H3	Communication with PCS		
		CAN_L3	Communication with PCS		
11	External signal input interface	5V0	Output DC5V/1A	Rear Panel	
		5V_GND	Output DC5V/1A		
		SIN1+	Input detection 1		
		SIN1-	Input detection 1		
		SIN2+	Input detection 2		
12	Dry contact interface	RLY-OUT1+	Dry contact 1 Output positive end	Rear Panel	
		RLY-OUT1-	Dry contact 1 Outputs the negative end		
		RLY-OUT2+	Dry contact 2 Output positive end		
		RLY-OUT2-	Dry contact 2 outputs the negative end		
		NC	Empty		
		NC	Empty		
13	Touch display	Display important information about the battery		Front Panel	
14	Ground the outer box	External box ground point		Rear Panel	

### BMS controller unit port description

Serial Num	Name	Description	Location	
1	Main switch	Manually control the connection between the battery and BCU	Front Panel	
2	PCS+	Connection terminal with PCS positive terminal (red)	Front Panel	
3	PCS-	Connection terminal with PCS negative terminal (black)	Front Panel	
4	Master/slave interface (Connection port for communication between the main control and the battery module)	CAN_H1	Slave control communication	Front Panel
		CAN_L1	Slave control communication	
		VO	Output positive from control power supply	
		P/GND	Output negative from control power supply	
		DN/-OP	Coded output from slave control	
		NC	Empty	
5	Start switch	System start/stop	Front Panel	
6	B-	Connection position of the negative battery pack (black)	Front Panel	
7	B+	Connection position of the positive battery pack (orange)	Front Panel	

### BMS controller unit parameters

ID	Items	Specifications/parameters	Remarks
1	Applicable platform	200 to 800 V	
2	Supply voltage	12~30 V	
3	Power consumption	<3 W	Static ≤0.3W
4	Current collection	200a/0.5%	
5	Total voltage collection	50~1650V	Sampling accuracy ±0.3%FSR
6	Temperature acquisition	-40 to 125 C ±2 C	Sampling period 200ms
7	Dry contact	DI detection (12V withstand voltage), external dry node signal (high voltage interlock, scram)	2 channels, max power 60W
8	Level of protection	IP21	
9	Dimensions (W x D x H)	517×512×175 mm	
10	Battery pack weight	~ 19 kg	

**Main control BCU box basic parameter settings**  
(Note: the following parameters are tested at 25°C unless otherwise specified)

ID	Indicator items			Factory default parameters	Whether can be set	Remarks		
1	Cell unit high voltage protection	Level 1	Cell unit over-voltage level 1 alarm voltage	3550mV	Can be set	Level 1, Level 2 only do alarms and do not cut off charging, level 3 cut off charging		
			Cell unit over-voltage level 1 alarm delay	3.0 S	Can be set			
			Cell unit over-voltage level 1 alarm recovery voltage	3500mV	Can be set			
			Cell unit over-voltage level 1 alarm recovery delay	2.0 S	Can be set			
		Level 2	Cell unit over-voltage level 2 alarm voltage	3600mV	Can be set			
			Cell unit over-voltage level 2 alarm delay	2.0 S	Can be set			
			Cell unit over-voltage level 2 alarm recovery voltage	3550mV	Can be set			
			Cell over-voltage level 2 alarm recovery delay	2.0 S	Can be set			
		Level 3	Cell unit over-voltage Level 3 protection voltage	3650mV	Can be set			
			Cell unit over-voltage level 3 protection delay	3.0 S	Can be set			
			Cell unit over-voltage level 3 protection release voltage	3400mV	Can be set			
			Cell unit over-voltage level 3 protection release delay	3.0 S	Can be set			
		Cell unit high voltage protection lifted	Discharge release	Discharge current >5.0A	Duration greater than 3S			
		2	Cell unit low-voltage protection	Level 1	Cell unit low voltage level 1 alarm voltage		2950mV	Can be set
					Cell unit low-voltage level 1 alarm delay		3.0 S	Can be set
					Cell unit low-voltage level 1 alarm recovery voltage		3050mV	Can be set
	Cell unit low-voltage level 1 alarm recovery delay				2.0 S		Can be set	
Level 2	Cell unit low voltage level 2 alarm voltage			2850mV	Can be set			
	Cell unit low-voltage level 2 alarm delay			2.0 S	Can be set			
	Cell unit low-voltage level 2 alarm recovery voltage			2950mV	Can be set			
	Cell unit low-voltage level 2 alarm recovery delay			2.0 S	Can be set			
Level 3	Cell unit low voltage level 3 protection voltage			2750mV	Can be set			
	Cell unit low voltage level 3 protection delay			3.0 S	Can be set			
	Cell unit low voltage level 3 protection release voltage			3850mV	Can be set			
	Cell unit low-voltage level 3 protection release delay			3.0 S	Can be set			
Cell unit low voltage protection release	Release when charges			Charge current >5.0A	Duration greater than 3S			
3	Pack high voltage protection			Level 1	Pack over-voltage level 1 alarm voltage	(3.55*N) V	Can be: (3.55*N) V	
					Pack over-voltage level 1 alarm delay	3.0 S	Can be set	
			Pack over-voltage level 1 alarm recovery voltage		(3.5*N) V	Can be: (3.5*N) V		
		Pack over-voltage level 1 alarm recovery delay	2.0 S		Can be set			

		Level 2	Pack over-voltage level 2 alarm voltage	(3.60*N) V	Can be: (3.60*N)V			
			Pack over-voltage level 2 alarm delay	2.0 S	Can be set			
			Pack over-voltage level 2 alarm recovery voltage	(3.55*N) V	Can be: (3.55*N)V			
			Pack over-voltage level 2 alarm recovery delay	2.0 S	Can be set			
			Level 3	Pack over-voltage level 3 protection voltage	(3.65*N) V		Can be: (3.65*N)V	
				Pack over-voltage level 3 protection delay	3.0 S		Can be set	
		Level 3	Pack overcharge level 3 protection release voltage	(3.40*N) V	Can be: (3.40*N)V			
			Pack overcharge level 3 protection release delay	3.0 S	Can be set			
		Pack over-voltage protection lifted	Discharge release	Discharge current >5.0A	Duration greater than 3S			
		4	Pack Low voltage protection	Level 1	Pack over-discharge level 1 alarm voltage		(2.9*N) V	Can be: (2.9*N)V
Pack overshoot level 1 alarm delay	3.0 S				Can be set			
Pack over-discharge level 1 alarm recovery voltage	(2.95*N) V				Can be: (2.95*N)V			
Pack overshoot level 1 alarm recovery delay	2.0 S				Can be set			
Level 2	Pack over-discharge level 2 alarm voltage			(2.8*N) V	Can be: (2.8*N)V			
	Pack overshoot level 2 alarm delay			2.0 S	Can be set			
	Pack over-discharge level 2 alarm recovery voltage			(2.85*N) V	Can be: (2.85*N)V			
	Pack overshoot level 2 alarm recovery delay			2.0 S	Can be set			
Level 3	Pack over-discharge level 3 protection voltage			(2.7*N) V	Can be: (2.7*N)V			
	Pack over-discharge level 3 protection delay			3.0 S	Can be set			
	Pack over-discharge level 3 protection release voltage			(2.75*N) V	Can be: (2.75*N)V			
	Pack over-discharge level 3 protection release delay			3.0 S	Can be set			
Pack over-release protection lifted	Release when charges			Charge current >5.0A	Duration greater than 3S			
5	Charge over-current protection			Level 1	Charge level 1 over-current protection current	70A	Can be set	10 consecutive times will lock the state, no longer automatically lifted
					Charging level 1 over-current protection delay	2.0 S	Can be set	
			Charge level 1 over-current protection Restore current		60 A	Can be set		
		Charge level 1 over-current protection restore delay	2.0 S		Can be set			
		Level 2	Charge level 2 over-current protection current	70A	Can be set			
			Charge level 2 over-current protection delay	2.0 S	Can be set			
		Level 3	Charge level 3 over-current protection current	80A	Can be set			
			Charge level 3 over-current protection delay	3.0 S	Can be set			

6	Charge over-current protection lifted		Automatic release	Automatically dissolves after 1 minute	Can be set	The status will be locked for 10 consecutive times and will not be automatically lifted
			Discharge release	Discharge current >5.0A	Duration greater than 3S	
	Discharge over-current protection	Level 1	Discharge level 1 over-current protection current	100A	Can be set	
			Discharge level 1 over-current protection delay	2.0 S	Can be set	
			Discharge level 1 over-current protection Restore current	80A	Can be set	
			Discharge level 1 over-current protection recovery delay	2.0 S	Can be set	
	Level 2	Discharge level 2 over-current to protect the current	100A	Can be set		
		Discharge level 2 over-current protection delay	2.0 S	Can be set		
	Level 3	Discharge level 3 over-current protection current	110A	Can be set		
		Discharge three over-current protection delay	3.0 S	Can be set		
Discharge over-current protection lifted		Automatic discharge	Automatically dissolves after 1 minute	Can be set		
		Charge release	Charge current >5.0A	Duration greater than 3S		
7	Charging high temperature cell temperature protection		Charging level 1 High temperature alarm temperature	50 °C	Can be set	
			Charge level 1 high temperature alarm delay	3.0 S	Can be set	
			Charge level 1 High temperature alarm recovery temperature	45 °C	Can be set	
			Charge level 1 high temperature alarm recovery delay	3.0 S	Can be set	
			Level 2	Charge level 2 High temperature alarm temperature	50 °C	Can be set
				Charge level 2 high temperature alarm delay	2.0 S	Can be set
				Charge level 2 High temperature alarm recovery temperature	45 °C	Can be set
				Charge level 2 high temperature alarm recovery delay	2.0 S	Can be set
			Level 3	Charge level 3 High temperature protection temperature	55 °C	Can be set
				Charging level 3 high temperature protection delay	3.0 S	Can be set
				Charge level 3 High temperature protection restore temperature	50 °C	Can be set
				Charge level 3 high temperature protection recovery delay	3.0 S	Can be set
	Discharge high temperature cell temperature protection		Discharge level 1 High temperature Alarm temperature	60 °C	Can be set	
			Discharge level 1 high temperature alarm delay	3.0 S	Can be set	
			Level1 high temperature alarm is cleared	55 °C	Can be set	
			Level 1 high temperature alarm recovery delay	3.0 S	Can be set	
			Level 2	Discharge level 2 High temperature Indicates the alarm temperature	60 °C	Can be set
				Discharge level 2 high temperature alarm delay	2.0 S	Can be set

	Charging low temperature cell temperature protection		Recovery temperature for the level 2 high temperature alarm	55 °C	Can be set	
			Delay in clearing a level 2 high temperature alarm	2.0 S	Can be set	
			Level 3	Discharge level 3 high temperature protection temperature	65 °C	Can be set
				Discharge level 3 high temperature protection delay	3.0 S	Can be set
				Discharge level 3 high temperature protection temperature recovery temperature	60 °C	Can be set
				Discharge level 3 high temperature protection temperature recovery delay	3.0 S	Can be set
	Level 1	Charge level 1 Low temperature Alarm temperature	5 °C	Can be set		
		Charge level 1 low temperature alarm delay	3.0 S	Can be set		
		Charge level 1 Low temperature alarm recovery temperature	8 °C	Can be set		
		Charge level 1 low temperature alarm recovery delay	3.0 S	Can be set		
		Level 2	Charge level 2 Low temperature Indicates the alarm temperature	2 °C	Can be set	
			Charge level 2 low temperature alarm delay	2.0 S	Can be set	
	Charge level 2 Low temperature alarm recovery temperature		5 °C	Can be set		
	Level 3	Charge level 2 low temperature alarm recovery delay	2.0 S	Can be set		
		Level 3 low temperature protection for charging	0 °C	Can be set		
		Charge level 3 low temperature protection delay	3.0 S	Can be set		
	Discharge low temperature cell temperature protection	Level 1	Charge level 3 low temperature protection restore temperature	3 °C	Can be set	
			Charge level 3 low temperature protection recovery delay	3.0 S	Can be set	
Discharge level 1 Low temperature Indicates the alarm temperature			- 5 °C	Can be set		
Discharge level 1 low temperature alarm delay			3.0 S	Can be set		
Level 2		Level 1 low temperature alarm is cleared	- 2 °C	Can be set		
		Level 1 low temperature alarm recovery delay	3.0 S	Can be set		
		Discharge level 2 Low temperature Indicates the alarm temperature	- 10 °C	Can be set		
		Discharge level 2 low temperature alarm delay	2.0 S	Can be set		
Level 3		Recovery temperature for the second-level low temperature alarm	- 7 °C	Can be set		
		Delay in clearing level 2 low temperature discharge alarm	2.0 S	Can be set		
		Discharge level 3 low temperature protection	-15 °C	Can be set		
		Discharge level 3 low temperature protection delay	3.0 S	Can be set		
Level 3	Discharge level 3 low temperature protection restore temperature	- 5 °C	Can be set			
	Discharge level 3 low temperature protection recovery delay	3.0 S	Can be set			

8	Ambient high temperature alarm	Level 1	Ambient level 1 High temperature Indicates the alarm temperature	55 °C	Can be set
			Environment level 1 high temperature alarm delay	3.0 S	Can be set
			Ambient level 1 high temperature recovery temperature	50 °C	Can be set
			Delay for clearing an ambient level 1 high temperature alarm	3.0 S	Can be set
		Level 2	Ambient level 2 high temperature alarm temperature	60 °C	Can be set
			Environment level 2 high temperature alarm delay	2.0 S	Can be set
			Ambient level 2 high temperature recovery temperature	55 °C	Can be set
			Delay for recovering an ambient level 2 high temperature alarm	2.0 S	Can be set
		Level 3	Environmental level 3 High temperature protection temperature	65 °C	Can be set
			Environmental level 3 high temperature protection delay	3.0 S	Can be set
			Environmental level 3 high temperature protection restore temperature	60 °C	Can be set
			Environmental level 3 high temperature protection recovery delay	3.0 S	Can be set
	Ambient low temperature alarm	Level 1	Ambient level 2 Low temperature Indicates the alarm temperature	- 10 °C	Can be set
			Environment Level 1 low temperature alarm delay	3.0 S	Can be set
			Ambient level 2 low temperature recovery temperature	- 7 °C	Can be set
			Environment level 1 low temperature alarm recovery delay	3.0 S	Can be set
		Level 2	Ambient low temperature level 2 Indicates the temperature of the alarm	-15 °C	Can be set
			Environment level 2 low temperature alarm delay	2.0 S	Can be set
			Ambient level 2 low temperature recovery temperature	- 12 °C	Can be set
			Delay for recovering an ambient low temperature alarm of level 2	2.0 S	Can be set

9	Terminal temperature protection	Level 3	Environmental level three low temperature protection temperature	- 20 °C	Can be set
			Environmental level 3 low temperature protection delay	3.0 S	Can be set
			Environmental level 3 low temperature protection restore temperature	- 10 °C	Can be set
			Environmental level 3 low temperature protection recovery delay	3.0 S	Can be set
		Level 1	Terminal level 1 high temperature alarm temperature	100 °C	Can be set
			Terminal level 1 high temperature alarm delay	3.0 S	Can be set
			Terminal Level 1 high temperature recovery temperature	80 °C	Can be set
			Terminal level 1 high temperature recovery delay	3.0 S	Can be set
		Level 2	Terminal level 2 high temperature alarm temperature	105 °C	Can be set
			Terminal level 2 high temperature alarm delay	2.0 S	Can be set
			Terminal level 2 high temperature recovery temperature	90 °C	Can be set
			Terminal level 2 high temperature recovery delay	2.0 S	Can be set
Level 3	Terminal level 3 high temperature protection temperature	110 °C	Can be set		
	Terminal level 3 high temperature protection delay	3.0 S	Can be set		
	Terminal level 3 high temperature protection release temperature	100 °C	Can be set		
	Terminal level 3 high temperature protection release delay	1.0 S	Can be set		
10	SOC High protection	Level 1	Level 1 SOC has a high alarm	95%	Can be set
			Level 1 SOC has a high alarm delay	3.0 S	Can be set
			Level 1 SOC high alarm is cleared	88%	Can be set
			Level 1 SOC High alarm recovery delay	3.0 S	Can be set
		Level 2	Level 2 SOC has a high alarm	95%	Can be set
			Level 2 SOC High alarm delay	2.0 S	Can be set
			Level 2 SOC High alarm cleared	93%	Can be set
			Level 2 SOC High alarm recovery delay	2.0 S	Can be set

The BMS does not use the SOC as the protection basis. The SOC is transferred to the EMS for scheduling

		Level 3	Level 3 SOC High protection	100%	Can be set	The BMS itself does not use SOC as the protection basis, and the SOC is uploaded to the EMS for scheduling	
			Level 3 SOC High protection delay	3.0 S	Can be set		
Level 3 SOC High recovery capacity	95%		Can be set				
Level 3 SOC High recovery delay	3.0 S		Can be set				
SOC High protection release		Discharge release	Discharge current >5.0A	Continuous current 3S			
11	SOC Low protection	Level 1	Level 1 SOC Low alarm	15%	Can be set		
			Level 1 SOC has low alarm latency	3.0 S	Can be set		
			Alarm is cleared when the level 1 SOC is low	18%	Can be set		
			Level 1 SOC Low alarm recovery delay	3.0 S	Can be set		
		Level 2	Level 2 SOC Low alarm	8%	Can be set		
			Low alarm delay for level 2 SOC	2.0 S	Can be set		
			Level 2 SOC low alarm is cleared	10%	Can be set		
			Level 2 SOC low alarm recovery delay	2.0 S	Can be set		
		Level 3	Level 3 SOC low protection	5%	Can be set		
			Level 3 SOC low protection delay	3.0 S	Can be set		
			Level 3 SOC with low recovery capacity	8%	Can be set		
			Level 3 SOC recovery delay	3.0 S	Can be set		
		SOC Low protection release		Charge release	Charge current >5.0A	Continuous current 3S	
		12	Positive insulation failure	Level 1	Level 1 positive insulation alarm	1000 Ω / V	Can be set
Level 1 positive insulation alarm delay	3.0 S				Can be set		
Level 2 positive insulation alarm is cleared	1200 Ω / V				Can be set		
Level 1 positive insulation alarm recovery delay	3.0 S				Can be set		
Level 2	Level 2 positive insulation alarm			600 Ω / V	Can be set		
	Level 2 positive insulation alarm delay			2.0 S	Can be set		
	Level 2 positive insulation alarm is cleared			800 Ω / V	Can be set		
	Level 2 positive insulation alarm recovery delay			2.0 S	Can be set		
Level 3	Level 3 positive insulation protection			200 Ω / V	Can be set		
	Level 3 positive insulation protection delay			3.0 S	Can be set		
	Level 3 positive insulation protection recovery			700 Ω / V	Can be set		
	Level 3 positive insulation protection recovery delay			3.0 S	Can be set		

	Negative insulation failure	Level 1	Level 1 negative insulation alarm	1000 Ω / V	Can be set		
			Level 1 negative insulation alarm delay	3.0 S	Can be set		
			Level 1 negative insulation alarm is cleared	1200 Ω / V	Can be set		
			Level 1 negative insulation alarm recovery delay	3.0 S	Can be set		
		Level 2	Level 2 negative insulation alarm	600 Ω / V	Can be set		
			Level 2 negative insulation alarm delay	2.0 S	Can be set		
			Level 2 negative insulation alarm is cleared	800 Ω / V	Can be set		
			Level 2 negative insulation alarm recovery delay	2.0 S	Can be set		
		Level 3	Level 3 negative insulation protection	200 Ω / V	Can be set		
			Level 3 negative insulation protection delay	3.0 S	Can be set		
			Level 3 negative insulation protection recovery	700 Ω / V	Can be set		
			Level 3 negative insulation protection recovery delay	3.0 S	Can be set		
		13	Charging cell differential voltage protection	Level 1	Level 1 charging cell voltage difference alarm	150mV	Can be set
					Level 1 charging cell voltage difference alarm delay	3.0 S	Can be set
Level 1 charge cell voltage difference recovery	100mV				Can be set		
Level 1 charge cell differential voltage recovery delay	3.0 S				Can be set		
Level 2	Level 2 charging cell voltage difference alarm			200mV	Can be set		
	Level 2 charging cell voltage difference alarm delay			2.0 S	Can be set		
	Level 2 charging cell differential voltage recovery			150mV	Can be set		
	Level 2 charge cell differential voltage recovery delay			2.0 S	Can be set		
Level 3	Level 3 charging cell differential voltage protection			250mV	Can be set		
	Level 3 charging cell differential voltage protection delay			3.0 S	Can be set		
	Level 3 charging cell differential voltage protection recovery			200mV	Can be set		
	Level 3 charging cell differential voltage protection recovery delay			3.0 S	Can be set		
Charge cell differential voltage protection lifted				Discharge release	Discharge current >5.0A	Continuous current 3S	
14	Discharge cell differential voltage protection			Level 1	Level 1 discharge cell voltage difference alarm	150mV	Can be set
		Level 1 discharge cell voltage difference alarm delay	3.0 S		Can be set		
		Level 1 discharge cell differential voltage recovery	100mV		Can be set		
		Level 1 discharge cell differential voltage recovery delay	3.0 S		Can be set		
		Level 2 discharge cell voltage difference alarm	200mV	Can be set			

		Level 2	Level 2 discharge cell voltage difference alarm delay	2.0 S	Can be set		
			Level 2 discharge cell differential voltage recovery	150mV	Can be set		
			Level 2 discharge cell differential voltage recovery delay	2.0 S	Can be set		
			Level 3	Level 3 discharge cell differential voltage protection	250mV	Can be set	
				Level 3 discharge cell differential voltage protection delay	3.0 S	Can be set	
				Level 3 discharge cell differential voltage protection recovery	200mV	Can be set	
		Level 3	Level 3 discharge cell differential voltage protection recovery delay	3.0 S	Can be set		
			Discharge cell differential voltage protection lifted	Charge release	Charge current >5.0A	Continuous current 3S	
		15	Charging cell temperature difference protection	Level 1	Level 1 charging cell temperature difference alarm	5 ℃	Can be set
					Level 1 charging cell temperature difference alarm delay	3.0 S	Can be set
The temperature difference alarm of the level 1 charging cell is cleared	3 ℃				Can be set		
Level 1 charging cell temperature difference alarm recovery delay	3.0 S				Can be set		
Level 2	Level 2 charging cell temperature difference alarm			8 ℃	Can be set		
	Two-stage charging cell temperature difference alarm delay			2.0 S	Can be set		
	The temperature difference alarm of the level 2 charging cell is cleared			6 ℃	Can be set		
	Recovery delay of temperature difference alarm of level 2 charging cell			2.0 S	Can be set		
Level 3	Level 3 charging cell temperature difference protection			10 ℃	Can be set		
	Level 3 charging cell temperature difference protection delay			3.0 S	Can be set		
	Level 3 charging cell temperature difference protection recovery			5 ℃	Can be set		
	level 3 charging cell temperature difference protection delay			3.0 S	Can be set		
16	Discharge cell temperature difference protection			Level 1	Level 1 discharge cell temperature difference alarm	5 ℃	Can be set
					Level 1 discharge cell temperature difference alarm delay	3.0 S	Can be set
					The temperature difference alarm of the level 1 discharge cell is cleared	3 ℃	Can be set
					Level 1 discharge cell temperature difference alarm recovery delay	3.0 S	Can be set
		Level 2	Level 2 discharge cell temperature difference alarm	8 ℃	Can be set		
			Level 2 discharge cell temperature difference alarm delay	2.0 S	Can be set		
			The temperature difference alarm of the level 2 discharge cell is cleared	6 ℃	Can be set		
			Level 2 discharge cell temperature difference alarm recovery delay	2.0 S	Can be set		
		Level 3	Level 3 discharge cell temperature difference protection	10 ℃	Can be set		
			Level 3 discharge cell temperature difference protection delay	3.0 S	Can be set		

			Level 3 discharge cell temperature difference protection recovery	5 ℃	Can be set
			Level 3 discharge cell temperature difference protection delay	3.0 S	Can be set
17	Cell temperature rise protection	Level 1	Level 1 battery temperature rise alarm	4 ℃/S	Can be set
			Level 1 cell temperature rise alarm delay	3.0 S	Can be set
			Level 1 battery temperature rise alarm is cleared	1 ℃/S	Can be set
			Level 1 cell temperature rise alarm recovery delay	3.0 S	Can be set
		Level 2	Level 2 cell temperature rise alarm	6 ℃/S	Can be set
			Level 2 cell temperature rise alarm delay	2.0 S	Can be set
			Level 2 cell temperature rise alarm is cleared	1 ℃/S	Can be set
			Level 2 cell temperature rise alarm recovery delay	2.0 S	Can be set
		Level 3	Level 3 cell temperature rise protection	8 ℃/S	Can be set
			Level 3 cell temperature rise protection delay	3.0 S	Can be set
			Level 3 cell temperature rise protection recovery	4 ℃/S	Can be set
			Level 3 cell temperature rise protection recovery delay	3.0 S	Can be set
18	Abnormal cell sampling	Level 1	Level 1 cell sampling abnormal delay	10.0 S	Can be set
			Level 1 cell sampling exception recovery delay	3.0 S	Can be set
		Level 2	Level 2 cell sampling abnormal delay	20.0 S	Can be set
			Level 2 cell sampling exception recovery delay	3.0 S	Can be set
		Level 3	Level 3 cell sampling abnormal delay	30.0 S	Can be set
			Level 3 cell sampling exception recovery delay	65.5 S	Can be set
19	NTC sampling exception	Level 1	Level 1 NTC sampling exception delay	1.0 S	Can be set
			Level 1 NTC sampling exception recovery delay	10.0 S	Can be set
		Level 2	Level 2 NTC sampling exception delay	3.0 S	Can be set
			Level 2 NTC sampling exception recovery delay	30.0 S	Can be set
		Level 3	Level 3 NTC sampling exception delay	5.0 S	Can be set
			Level 3 NTC sampling exception recovery delay	30.0 S	Can be set
20	Battery cell failure	Cell failure differential voltage	1000mV	Can be set	
		Cell fault delay	5.0 S	Can be set	
		Cell failure recovery differential voltage	500mV	Can be set	
		Cell fault recovery delay	1.0 S	Can be set	

21	Relay failure	Relay sticking	Power off the system completely		
22	Balancing function	Equalizing on voltage	3400mV	Can be set	
		Open I voltage difference	30mV	Can be set	
23	Full charge judgment	Cut-off current	< 2A	Can be set	At the same time meet after stopping charging and more 100% for new SOC
		Full charge voltage	Total voltage> single pack voltage * number of BMUs V	Can be set (cell voltage: 3.5V*number of BMU strings*number of BMUs)	
24	Consuming current	Consumes electricity while working		≤3W (excluding relay driven current)	
		Shutdown mode current		≤0.3W	
25	Severe Low voltage protection	Cell < 2600mV	At rest for 20 minutes, discharge for 20S	Power off the system	
		Cell < 2000mV	4S		
26	Severe high voltage protection	Cell > 3800mV	4S	1	

## 5.10 Screen instructions

### 1. Main interface

After power-on/hibernation activation, the main screen of the system will be displayed, as shown in the following figure:



### 3. Temperature Info Page

When selecting the "Temperature Information" item, click to enter the "Battery Temperature Status" page, as shown below:



### 5. Key description

1. Each page can be accessed by clicking "Next" or "Back to Previous Page" to operate the interface.
2. Click "Back to Home" to return to the main interface.
3. In the dormant state, touch anywhere on the screen to activate the display.

### 2. Option page surface

After selecting the module information that you want to view, the main screen will be displayed as follows:



### 4. Battery voltage information page

When selecting "Cell Voltage", click to enter the "Battery Voltage status" page, as shown below:



## 6. Sleep/Shutdown

In normal operation, the system will enter the hibernation/shutdown state after 3 minutes of keyless operation.

In the shutdown/hibernate state, operate any button, the display will be activated and the main status interface will be entered.

## 6. Maintain and upgrade

Note: All maintenance work should comply with applicable local regulations and standards.

### 6.1 System maintenance

All plug connections must be checked to ensure safe operation. If necessary, the relevant operator should press them back into place at least once a year.

The following inspections or maintenance must be performed annually.

1. Visual inspection in general .
2. Check all tight electrical connections and must re-tighten loose connections.
3. Use monitoring software to check the SOC, SOH, battery voltage and temperature of the battery module for abnormalities.
4. Shut down and restart the battery system once a year.

Note: If the system is installed in a contaminated environment, it must be maintained and cleaned for a short time. Clean the battery holder with a dry cloth to ensure that no moisture is in contact with the battery connection, and do not use solvents.

### 6.2 System upgrade

Please contact the manufacturer to provide the relevant upgrade documentation and complete the upgrade under their guidance.

## 7. Store of the batteries

1. In order to ensure the lifespan of the battery, the storage temperature should be maintained between 0 ° C ~35 ° C.
2. The battery should be cycled at least every 3-6 months.
3. In order to minimize self-discharge during storage for long time, please disconnect the battery connection of the high voltage control box from the DC connection harness.

## 8. Disposal of waste batteries

Note: Comply with the relevant regulations of waste battery disposal. Stop using damaged batteries immediately. Contact your installer or sales partner before disposing of it. Make sure the battery is not exposed to moisture or direct sunlight.

1. Do not dispose of the battery as household waste! You have a legal obligation to return used and rechargeable batteries.
2. Used batteries may contain contaminants that, if stored or disposed of improperly, may do harm to the environment or health.
3. Batteries also contain iron, lithium and other important raw materials that can be recycled.



## 9. Maintenance and conservation

Item	Problem description	Description/ possible causes	Solution
1	Unable to boot properly, BMS will immediately enter the protection state after press the switch	The external load does not match, and the instantaneous current of load startup is too large	1. Press the on key to restart 2. Reduce load power
2	Automatically disconnect the output during use	1. The battery voltage is too low 2. Output or load short circuit	1. Charge the battery 2. Disconnect the load and restart the battery
3	The Communication fault occurs when the load is inverter	1. Communication line connection error (connecting pin improper connection or oxidation) 2. The internal protocol code of inverter is not properly chosen 3. Communication insert loose or improper connection	1. Check the connection between BMS and inverter 2. Choose the corresponding communication protocol in the inverter's internal program 3. Reconnect the communication cables. If the problem still-exists' please contact the manufacturer
4			
5			
6			

In order to maintain the best and long-term performance, the following items are recommended to be inspected twice a year.

1. Confirm that the surrounding air flow will not be blocked, and remove any dirt and debris on the cooling hole.
2. Check all exposed wires, shabby and damage, please replace or repair them if necessary.
3. If it is not used for a long time, it is recommended to charge it every three months.



**Danger of electric shock! Make sure that the power supply has been disconnected during the above operations, and then carry out corresponding inspection and operation.**

## 10. Product Warranty Record Card

Dear Users,

Hello! Thank you very much for purchasing our company's products, in order to better serve you, please read carefully, fill in and after purchasing the products Keep this warranty card to avoid your worries, the company hereby makes a warranty service commitment, and provides specifications accordingly After-sales service.

Exclusion of warranty liability:

1. Damage caused by man-made reasons or other natural disasters;
2. Failure caused by incorrect operation, installation or use in an environment other than the use specified by the product;
3. Damage caused by unauthorized disassembly and modification;

Contact: \_\_\_\_\_ Numbering: \_\_\_\_\_

Contact Number: \_\_\_\_\_ Fax: \_\_\_\_\_

Purchase Date: \_\_\_\_\_

Address: \_\_\_\_\_

Maintenance records			
Drop-in date	Repair content	Maintenance people	Remark